

PRODUCER



Services and Trade Company

"EKO-WIN" Sp. z o.o.

10-467 Olsztyn, ul. Sprzętowa 3/14

tel./fax: + 48 (89) 539 19 66

e-mail: ekowin@ekowin.pl

www.ekowin.eu

TECHNICAL DATA-SHEET



Multi-Voltage Mining Fan WWG-1000/2x37

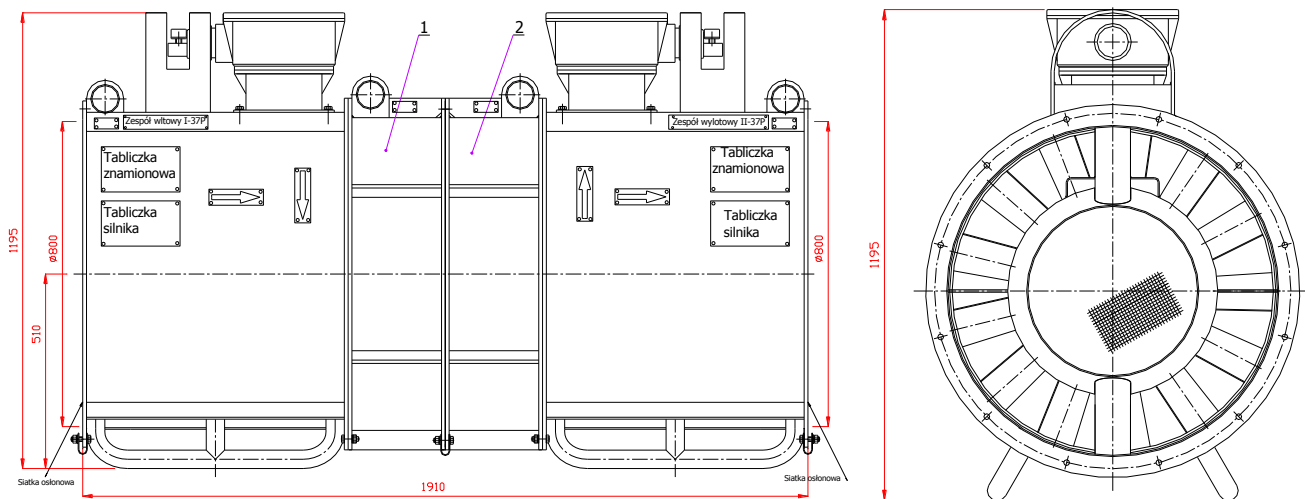

1. Set of inlet I-37; 2. Steering I-37

Table. Key technical parameters of the Multi-Voltage Mining Fans type WWG-1000/2x37

Parameter	Unit of Measure	WWG-1000/2x37
Nominal capacity ⁽¹⁾	m ³ /min	620
Capacity range	m ³ /min	560 ÷ 720
Pressure - nominal	Pa	4600/5150
Diameter of fan	mm	800
Diameter of ventilation ducts	mm	600, 800, 1000, 1200
Weight	kg	ok. 1355
Type of electric motor	-	dSOKg 200L2B-E
• Nominal supply voltage ⁽²⁾	V	500 or 1000
• Power of electric motor	kW	37
Corrosion protection	-	zinc-plated

(1) On customer request nominal parameters of work can be changed within the 400 do 620 m³/min (for example 450, 500 m³/min).

(2) Other voltage according to manual of electric motor D4-34.460 edition VI.

Scope of using

- The Multi-Voltage Mining Fans type WWG-1000/2x37 are designed for ventilation of mining excavations by a separate ventilation and to cooperate with the dust collectors or air conditioning.
- The Multi-Voltage Mining Fans type WWG-1000/2x37 are adapted to work in mines, in which there is methane hazard (excavation with degree of „a”, „b” and „c” of methane explosion hazard) and coal dust explosion hazard (excavation with class of „A” and „B” of coal dust explosion hazard). Devices are comply with the requirements of the Minister of Economy of 22 December 2005 (Journal of Laws No. 263 of 2005, item 2203) and they are devices of group I category M2.

- The fans can also be used outside of mining in other industrial sectors, e.g. in coal processing plant. The fan are designed for continuous use.
- Reliability characterized WWG type fans. The high parameters of ram effect and capacity while also high efficiency are achieved by using 37 kW of electric motors type dSOKg 200 L2B-E. Rotor blades are made of hard-wearing steel.
- The modified of the rotor casing reduces flow resistance and improve airflow.
- In the fans can be apply additional commercial equipments: a set of silencers that are comply with the requirements of PN-81/N-01306 and PN-N 01307:1994 for acoustic protection, elements to reduce the loss of fans ram effect, e.g.: inlets, diffusers, confusors, set of reduction connectors to the cooperation with ventilation ducts diameter from 600 to 1200 mm.
- It is possible to change parameters of the fan, in accordance with the requirements of the Customer.

Characteristic curves for the fans type WWG-1000/2x37

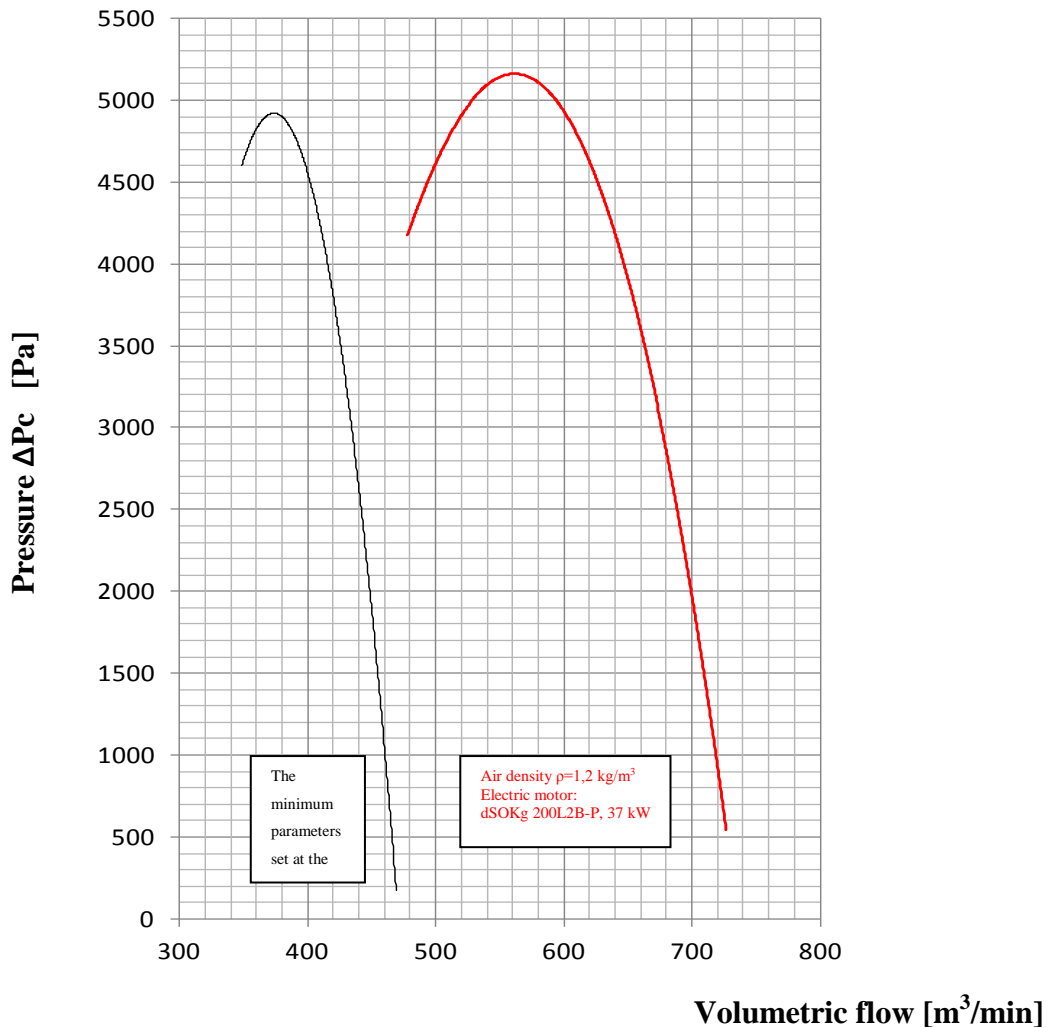

Multi-Voltage Mining Fan WWG-1000/2x37 is certified
The Certificate of Conformity No. OBAC 14 CZ/ATEX 0037X,
issued by The „OBAC” Institute for Research and Certification Ltd. (No. 1461).

Recommended silencers for the fans type WWG-1000/2x37

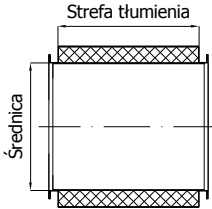
	Type of silencer	Diameter mm	Length of damping area mm	Minimal effectiveness
	UTH-800	800	1250	19,70 dB(A)
	UTH-1000	1000	1250	18,42 dB(A)
	TG Ø800/1100	800	1100	16 dB(A)
	TG Ø1000/800	1000	800	14 dB(A)
	TG Ø1000/1100	1000	1100	16 dB(A)