

PRODUCER



Services and Trade Company

"EKO-WIN" Sp. z o.o.

10-467 Olsztyn, ul. Sprzętowa 3/14

tel./fax: + 48 (89) 539 19 66

e-mail: ekowin@ekowin.eu

www.ekowin.eu

## TECHNICAL DATA-SHEET



# Multi-Voltage Mining Fan WWG-1000B/80/2N/P

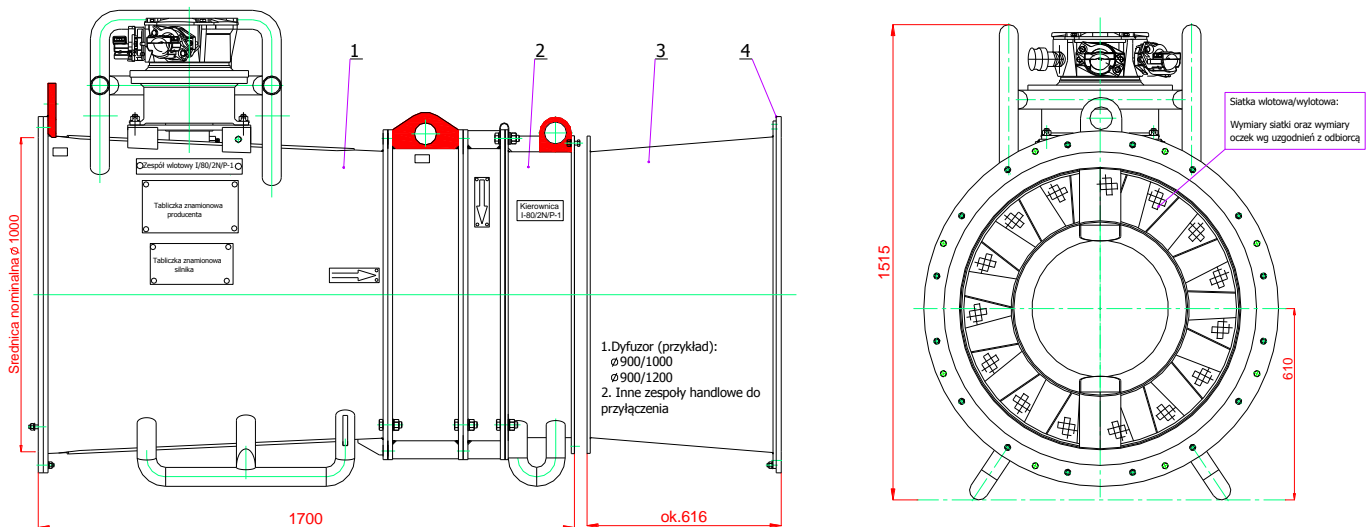

1. Set of inlet; 2. Steering; 3. Diffuser; 4. Grille

**Table. Key technical parameters of the Multi-Voltage Mining Fans type WWG-1000B/80/2N/P**

Parameter	Unit of Measure	WWG-1000B/80/2N/P
Nominal capacity speed I / speed II	m <sup>3</sup> /min	450 / 900
Capacity range speed I / speed II	m <sup>3</sup> /min	450÷600 / 900÷1200
Total ram effect – nominal speed I / speed II	Pa	700/3000
Diameter of fan	mm	1000
Diameter of ventilation ducts	mm	800, 1000, 1200
Weight	kg	about 1780
Type of electric motor	-	dSOKgsk225L4/2N-P
• Nominal supply voltage	V	500 / 1000
• Power of electric motor speed I / speed II	kW	15 / 80
Corrosion protection	-	zinc-plated

\* In accordance with the requirements of the Customer nominal operating parameters may be changed, while keeping motor power of 80 kW. The engine can be operated at air density  $\rho = 1,4 \text{ kg/m}^3$ .

## Scope of using

- The Multi-Voltage Mining Fans type WWG-1000B/80/2N/P are designed for ventilation of mining excavations by a separate ventilation and to cooperate with the dust collectors or air conditioning.
- The Multi-Voltage Mining Fans type WWG-1000 are adapted to work in mines, in which there is methane hazard (excavation with degree of „a”, „b” and „c” of methane explosion hazard) and coal dust explosion hazard (excavation with class of „A” and „B” of coal dust explosion hazard). Devices are comply with the requirements of the Minister of Economy of 22 December 2005 (Journal of Laws No. 263 of 2005, item 2203) and they are devices of group I category M2.
- The fans can also be used outside of mining in other industrial sectors, e.g. in coal processing plant. The fan are designed for continuous use.
- Reliability characterized WWG type fans. The high parameters of ram effect and capacity while also high efficiency are achieved by using 80 kW of electric motors type dSOKgsk225L4/2N-P. Rotor blades are made of hard-wearing steel.
- In the fans can be apply additional commercial equipments: a set of silencers that are comply with the requirements of PN-81/N-01306 and PN-N 01307:1994 for acoustic protection, elements to reduce the loss of fans ram effect, e.g.: inlets, diffusers, confusers, set of reduction connectors to the cooperation with ventilation ducts diameter from 800 to 1200 mm.
- It is possible to change parameters of the fan, in accordance with the requirements of the Customer.

### Characteristic curves for the fans type WWG-1000B/80/2N/P

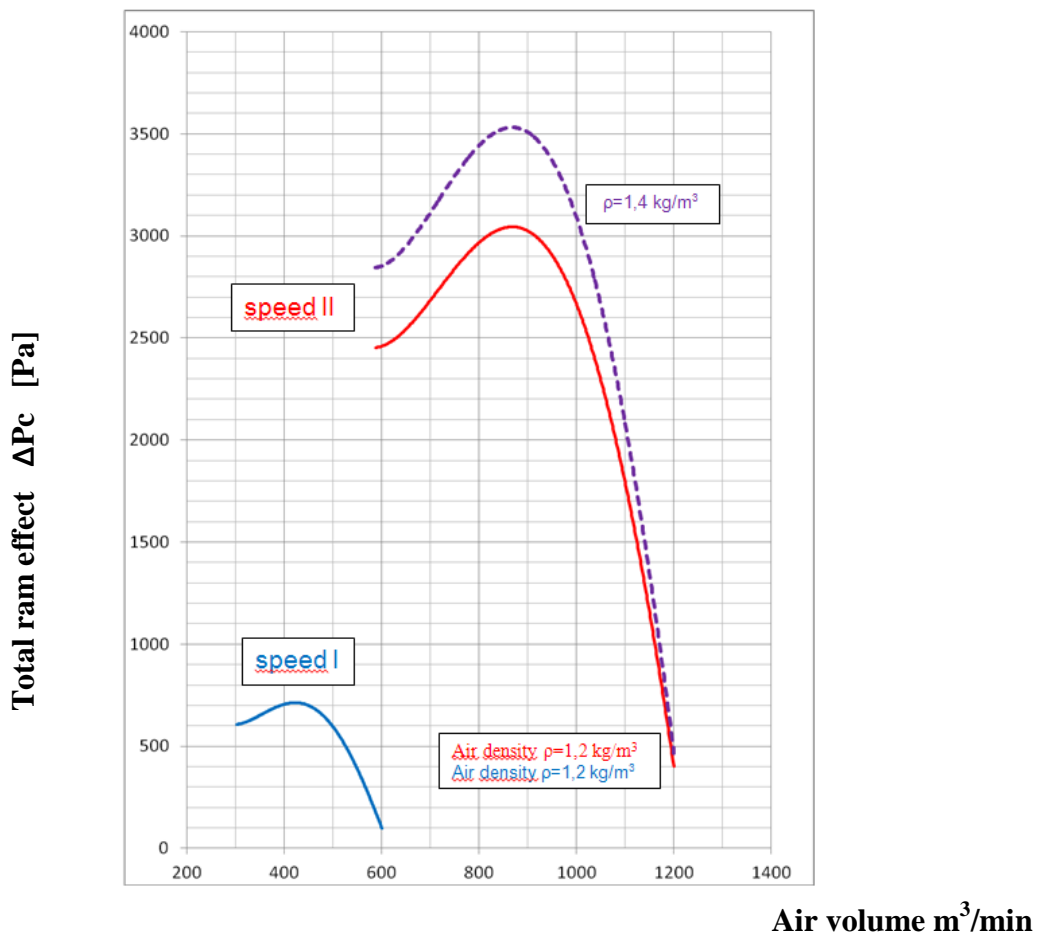

**Multi-Voltage Mining Fan WWG-1000B/80/2N/P-1 is in the course of certification.**

### Recommended silencers for the fans type WWG-1000B/80/2N/P

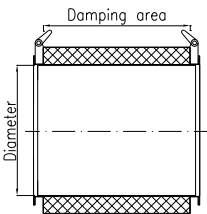
	Type of silencer	Diameter mm	Length of damping area mm	Minimal effectiveness
	UTH-1000	1000	1250	18,42 dB(A)
	TG Ø1000/1100	1000	1100	16 dB(A)